

FITTING REPORT
CYCLIST'S DOCUMENT



CYCLIST NAME
CYCLIST ID
FITTER ID

FITTING NO.
BICYCLE

GOAL

ACTIONS

RECOMMENDATIONS

FITTING REPORT

CYCLIST'S DOCUMENT

CYCLIST ID
 FITTER ID
 FITTING NO.
 BICYCLE

DIMENSIONS

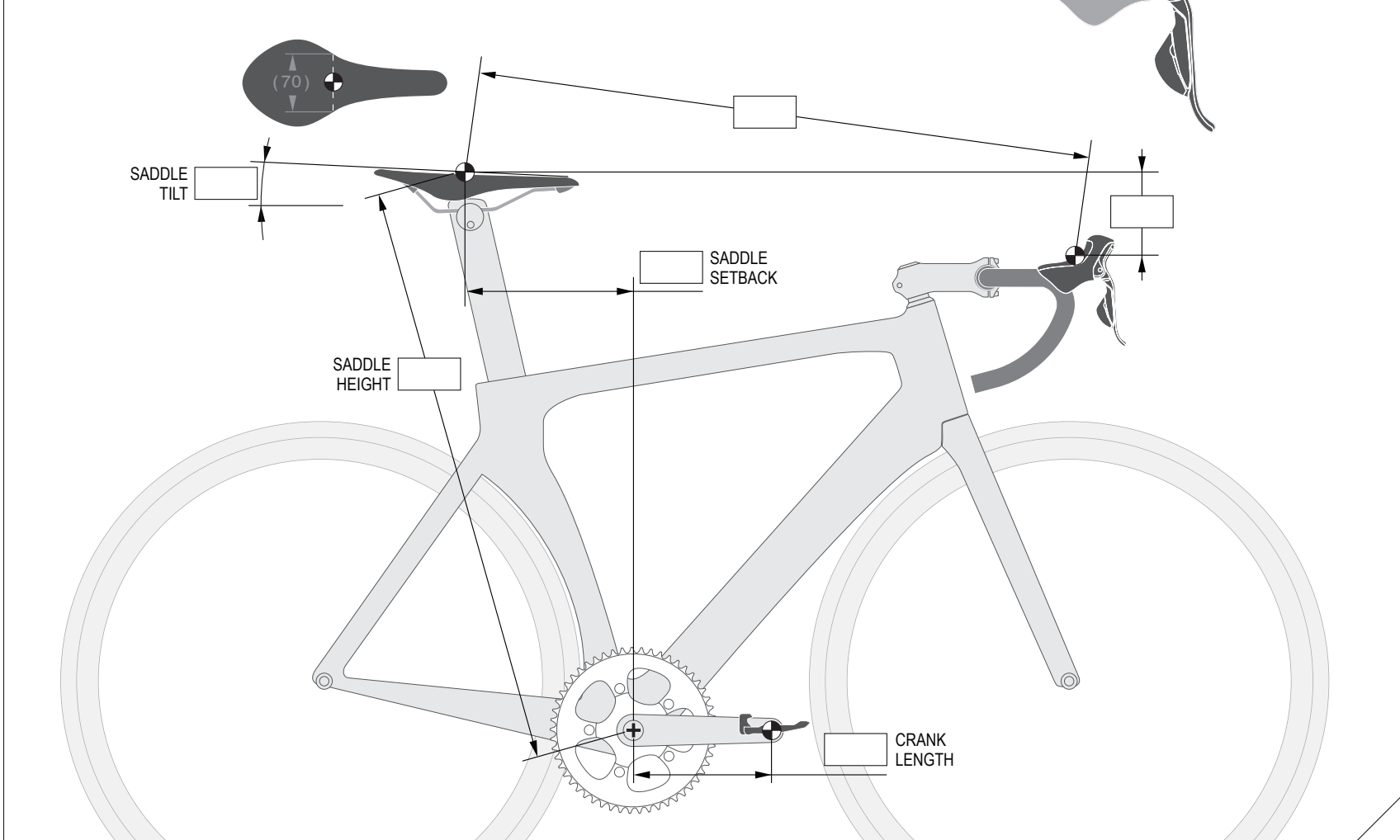
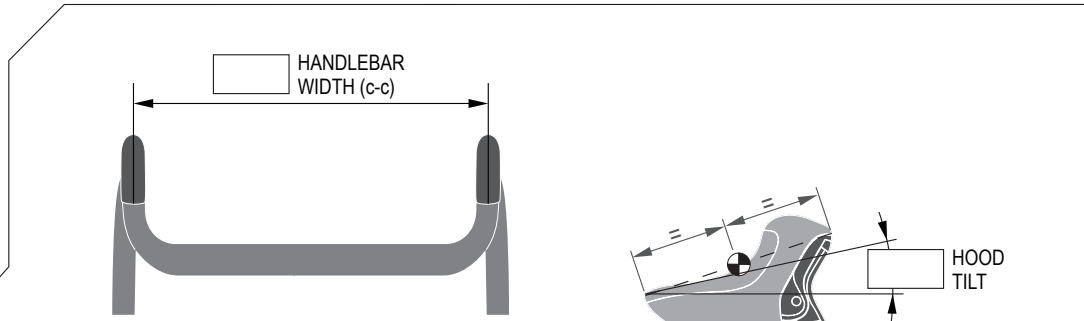

FRAME

BRAND

MODEL

YEAR

SIZE

PEDALS

BRAND

MODEL

FLOATING

SADDLE

BRAND

MODEL

HOODS

BRAND

MODEL

YEAR